

DATA SHEET



T 8091 EN

Type 3510-1 and Type 3510-7 Pneumatic Control Valves

Type 3510 Micro-flow Valve

DIN version



Application

Control valve especially designed for controlling low flow rates in pilot plants and technical research facilities

Valve size G 1/8 · G 1/4 · G 3/8 · G 1/2 · G 3/4
1/8 NPT · 1/4 NPT · 3/8 NPT · 1/2 NPT · 3/4 NPT
DN 10 · DN 15 · DN 25

Pressure rating PN 40 to 400

Temperatures -196 to +450 °C

Type 3510 Micro-flow Valve with

- Type 3271-5 Pneumatic Actuator
- Type 3277-5 Pneumatic Actuator

Available as

- Globe valve
- Angle valve

Valve body with

- G or NPT female thread
- Welding ends or flanges

Stainless steel is used as the standard body material. However, a wide variety of special materials can also be used on customer request.

A mounting kit (1400-9031) provides the valve with an interface according to IEC 60534-6-1 (NAMUR) for attachment of positioners, limit switches, solenoid valves and other valve accessories. We recommend using an insulating section or bellows seal for flanged valves to provide more space to mount valve accessories.

Standard version

- For temperatures from -10 to +220 °C
- PN 40 to 400
- Globe or angle valve
- Female thread G 1/8 · G 1/4 · G 3/8 · G 1/2 · G 3/4 or 1/8 NPT, 1/4 NPT, 3/8 NPT, 1/2 NPT, 3/4 NPT
- Flanges DN 10, 15 or 25
- Welding ends DN 10, 15 or 25

Type 3510-1 · With Type 3271-5 Pneumatic Actuator (120 cm²) · See Data Sheet ▶ T 8310-1

Type 3510-7 (Fig. 1 and Fig. 2) · With Type 3277-5 Pneumatic Actuator (120 cm²) for integral positioner attachment · See Data Sheet ▶ T 8310-1

Further versions

- **Insulating section** for temperatures from -196 to +450 °C, with special material up to +650 °C

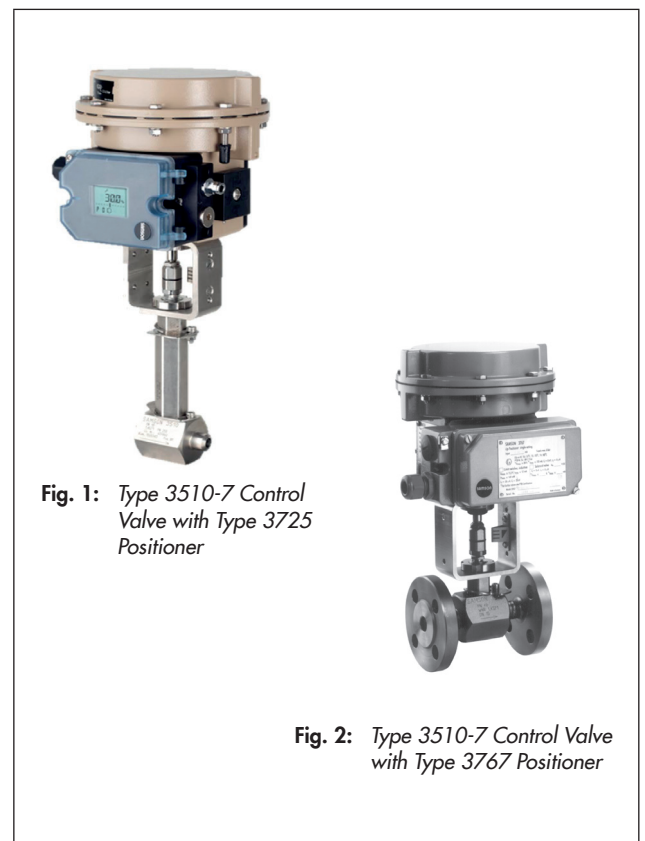

Fig. 1: Type 3510-7 Control Valve with Type 3725 Positioner

Fig. 2: Type 3510-7 Control Valve with Type 3767 Positioner

- **Metal bellows seal** up to PN 250 or PN 325 with a sealing performance of $\leq 10^{-5}$ (mbar l)/s
- **Handwheel**
- **Electric actuator** · On request
- **Stainless steel actuator** for ambient temperatures down to -60 °C · On request
- **Body connections with threaded flanges** and lens ring gaskets in valve sizes DN 6 and 10, nominal pressure PN 325, dimensions acc. to IG standard ($K_{V_{Smax}} = 0.4$)

Principle of operation

The medium flows through the micro-flow valve in the direction indicated by the arrow. The plug position determines the cross-sectional area between the seat and plug.

The plug stem is connected to the actuator stem by the stem connector and sealed with an adjustable packing.

To comply with stricter environmental emissions requirements, the valve can be equipped with a double-walled metal bellows.

The anti-rotation fixture prevents a loosening of the screw connection between the valve body and the bonnet or the intermediate piece.

Fail-safe position

Depending on how the springs are arranged in the pneumatic actuator (► T 8310-1), the valve has two different fail-safe positions.

- **Actuator stem extends (fail-close)**
The valve closes when the supply air fails.
- **Actuator stem retracts (fail-open)**
The valve opens when the supply air fails.

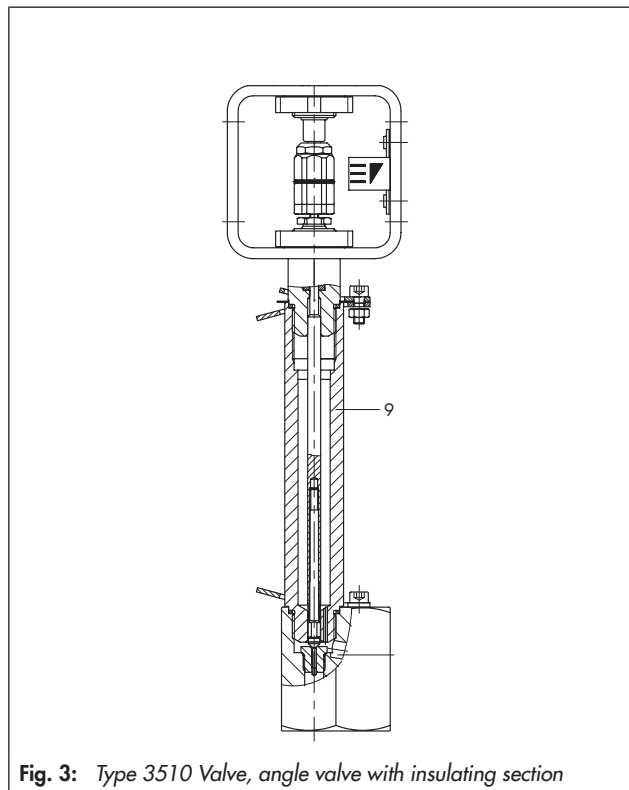

Fig. 3: Type 3510 Valve, angle valve with insulating section

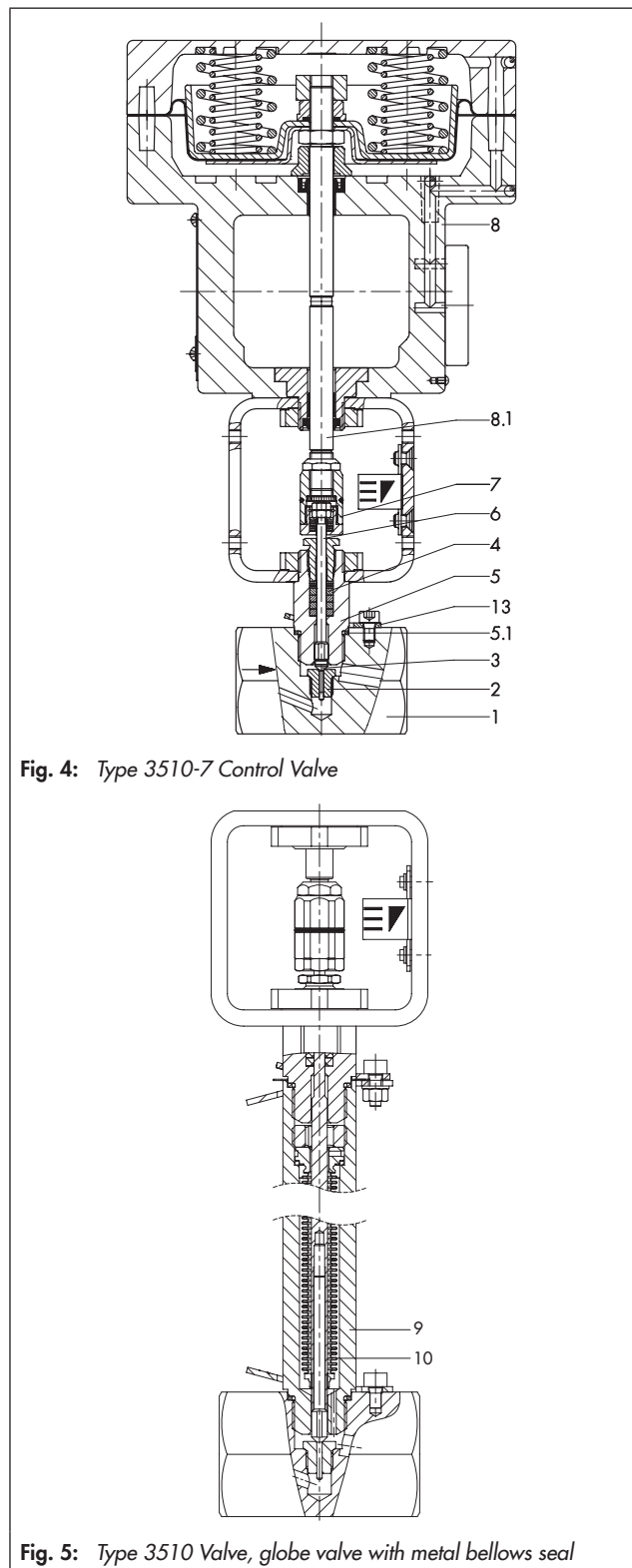

Fig. 4: Type 3510-7 Control Valve

Fig. 5: Type 3510 Valve, globe valve with metal bellows seal

Legend for Fig. 3, Fig. 4 and Fig. 5

- | | |
|-----------------|---|
| 1 Valve body | 7 Stem connector |
| 2 Seat | 8 Actuator |
| 3 Plug | 8.1 Actuator stem |
| 4 Packing | 9 Intermediate piece for
Insulating section or bellows
seal |
| 5 Valve bonnet | 10 Metal bellows |
| 5.1 Body gasket | 13 Anti-rotation fixture |
| 6 Plug stem | |

Table 1: Technical data for Type 3510

Connection	Female thread	Welding ends	Flanges
Valve size	G 1/8 · G 1/4 · G 3/8 · G 1/2 · G 3/4 1/8 NPT, 1/4 NPT, 3/8 NPT, 1/2 NPT, 3/4 NPT	DN 10 · DN 15 · DN 25	DN 10 · DN 15 · DN 25
Pressure rating	PN 40 to 400		
Seat-plug seal	Metal seal		
Characteristic	Equal percentage with $K_{VS} \geq 0.01$ · Linear · On/off		
Rangeability	50:1 · < 50:1 with $K_{VS} < 0.1$		
Temperature range ¹⁾	-10 to +220 °C · With insulating section: -196 to +450 °C		
Leakage class according to IEC 60534-4	Metal seal: IV · High-performance metal seal: V		
Conformity	CE · UK · EAC		

¹⁾ Higher temperatures on request

Table 2: Materials

Valve body ¹⁾ and valve bonnet ²⁾	1.4401/1.4404 ⁴⁾	2.4610
Seat	1.4401/1.4404 ^{3) 4)} 1.4122 Stellite®	2.4610 ³⁾
Plug	1.4401/1.4404 ^{3) 4)} 1.4112 Stellite®	2.4610 ³⁾
Packing	PTFE compound	
Body gasket	1.4401/1.4404 ⁴⁾	2.4610
Insulating section	1.4401/1.4404 ⁴⁾	2.4610
Metal bellows seal		
Intermediate piece	1.4401/1.4404 ⁴⁾	2.4610
Metal bellows up to PN 250	1.4571	2.4819
Metal bellows up to PN 325	2.4819	2.4819

¹⁾ Other materials on request

²⁾ Wetted parts

³⁾ Only with K_{VS} 0.001 to 1.6

⁴⁾ Material double stamping

Table 3: Available K_{VS} coefficients

Table 3.1: Overview

K_{VS} coefficient		0.0001 to 0.0063 ¹⁾	0.01 to 0.25	0.4	0.63 to 1.6 ²⁾
Rangeability		<15 : 1	15:1 to 50:1	50 : 1	
Seat Ø	mm	2	3	4	10
Seat thread ³⁾		M10x1			M16x1
Plug stem Ø	mm	4		4	
Travel	mm	7.5		7.5	

¹⁾ Seat and plug made only of 1.4122/1.4112, 1.4122/Stellite® or Stellite®/Stellite®

²⁾ Only up to PN 100

³⁾ Trims are only interchangeable within the K_{VS} coefficient ranges K_{VS} 0.0001 to 0.4 (M10x1) and K_{VS} 0.63 to 1.6 (M16x1) due to the different seat threads.

Table 3.2: K_{VS} coefficients and associated valve sizes

Flow coefficient K_{VS}	Connection		Female thread			Welding ends			Flanges		
	Equal percentage	Linear	G 1/8 · G 1/4 · 1/8 NPT · 1/4 NPT	G 3/8 · 3/8 NPT	G 1/2 · G 3/4 · 1/2 NPT · 3/4 NPT	DN 10	DN 15	DN 25	DN 10	DN 15	DN 25
0.00010	-	•	•	•	•	•	•	•	•	•	•
0.00016		•	•	•	•	•	•	•	•	•	•
0.00025		•	•	•	•	•	•	•	•	•	•
0.00040		•	•	•	•	•	•	•	•	•	•
0.00063		•	•	•	•	•	•	•	•	•	•
0.0010		•	•	•	•	•	•	•	•	•	•
0.0016		•	•	•	•	•	•	•	•	•	•
0.0025		•	•	•	•	•	•	•	•	•	•
0.0040		•	•	•	•	•	•	•	•	•	•
0.0063		•	•	•	•	•	•	•	•	•	•
0.010		•	•	•	•	•	•	•	•	•	•
0.016	•	•	•	•	•	•	•	•	•	•	
0.025	•	•	•	•	•	•	•	•	•	•	
0.040	•	•	•	•	•	•	•	•	•	•	
0.063	•	•	•	•	•	•	•	•	•	•	
0.10	•	•	•	•	•	•	•	•	•	•	
0.16	•	•	•	•	•	•	•	•	•	•	
0.25	•	•	•	•	•	•	•	•	•	•	
0.40	•	•	•	•	•	•	•	•	•	•	
0.63 ¹⁾	•	•	-	•	-	•	•	-	•	•	
1.0 ¹⁾	•	•		•		•	•				
1.6 ¹⁾	•	•		•		•	•				

¹⁾ Versions can be used up to PN 100 at the maximum

Table 3.3: Valve selection guide

PN	16 to 40		63 to 100		160 to 250		325		400		
Metal bellows	Optional		Optional		Optional		Optional		-	Optional	
K_{VS}											
0.0001	Type 3510		Type 3510		Type 3510		Type 3510		Type 3510		
0.00016											
0.00025											
0.0004											
0.00063											
0.001											
0.0016											
0.0025											
0.004											
0.0063											
0.01											
0.016											
0.025											
0.04											
0.063											
0.1											
0.16											
0.25											
0.4		Type 3252		Type 3252		Type 3252		Type 3252			
0.63		Type 3241		Type 3251		Type 3252		Type 3251			
1											
1.6											
2.5											
4											
6.3											
10											

Detailed information on each valve can be found in the following data sheets:

- Type 3241: ▶ T 8015 (DIN) and ▶ T 8012 (ANSI)
- Type 3251: ▶ T 8051 (DIN) and ▶ T 8052 (ANSI)
- Type 3252: ▶ T 8053

Table 4: Permissible differential pressures · Pressures stated in bar (gauge)

Table 4.1: Standard version without bellows seal · Fail-close · Maximum permissible supply pressure: 4 bar

Bench range with actuator area		120 cm ²	0.8 to 1.6	1.7 to 2.1	2.4 to 3.0
Valve size	K _{V5} coefficient	Actuator	Δp when p ₂ = 0 bar		
G 1/8 · G 1/4 · G 3/8 · G 1/2 · G 3/4 1/8 NPT, 1/4 NPT, 3/8 NPT, 1/2 NPT, 3/4 NPT DN 10 · DN 15 · DN 25	0.0001 to 0.4	120 cm ²	400	–	–
G 1/2 · G 3/4 1/2 NPT · 3/4 NPT DN 15 · DN 25	0.63 to 1.6	120 cm ²	84	100	–

Table 4.2: Standard version with bellows seal · Fail-close · Maximum permissible supply pressure: 4 bar

Bench range with actuator area		120 cm ²	0.8 to 1.6	1.7 to 2.1	2.4 to 3.0	2.4 to 3.0
Valve size	K _{V5} coefficient	Actuator	Δp when p ₂ = 0 bar			
G 1/8 · G 1/4 · G 3/8 · G 1/2 · G 3/4 1/8 NPT, 1/4 NPT, 3/8 NPT, 1/2 NPT, 3/4 NPT DN 10 · DN 15 · DN 25	0.0001 to 0.4	120 cm ²	72	160	250	325
G 1/2 · G 3/4 1/2 NPT · 3/4 NPT DN 15 · DN 25	0.63 to 1.6	120 cm ²	68	100	–	–

Table 4.3: Standard version without bellows seal · Fail-open · Maximum permissible supply pressure: see Table 4.5

Bench range with actuator area		120 cm ²	0.8 to 1.6		
		Supply pressure	2.0	3.3	4.3
Valve size	K _{V5} coefficient	Actuator	Δp when p ₂ = 0 bar		
G 1/8 · G 1/4 · G 3/8 · G 1/2 · G 3/4 1/8 NPT, 1/4 NPT, 3/8 NPT, 1/2 NPT, 3/4 NPT DN 10 · DN 15 · DN 25	0.0001 to 0.4	120 cm ²	254	400	–
G 1/2 · G 3/4 1/2 NPT · 3/4 NPT DN 15 · DN 25	0.63 to 1.6	120 cm ²	36	100	–

Table 4.4: Standard version with bellows seal · Fail-open · Maximum permissible supply pressure: see Table 4.5

Bench range with actuator area		120 cm ²	0.8 to 1.6			
		Supply pressure	2.0	3.3	4.3	4.3
Valve size	K _{V5} coefficient	Actuator	Δp when p ₂ = 0 bar			
G 1/8 · G 1/4 · G 3/8 · G 1/2 · G 3/4 1/8 NPT, 1/4 NPT, 3/8 NPT, 1/2 NPT, 3/4 NPT DN 10 · DN 15 · DN 25	0.0001 to 0.4	120 cm ²	27	160	250	325
G 1/2 · G 3/4 1/2 NPT · 3/4 NPT DN 15 · DN 25	0.63 to 1.6	120 cm ²	27	100	–	–

Table 4.5: Maximum permissible supply pressure for fail-open version

Bench range	Adjusted to	Max. permissible supply pressure
0.4 to 2.0	0.8 to 1.6	3.3
1.4 to 2.3	1.7 to 2.1	3.8
2.1 to 3.3	2.4 to 3.0	4.7

Table 5: Dimensions in mm**Table 5.1:** Type 3510 Valve

Port		Female thread	Welding ends	Flanges		
Valve		G/NPT	DN 10, 15, 25	DN 10	DN 15	DN 25
L ¹⁾	PN 40	74	80	130	130	160
	PN 63 to 160			210	210	230
	PN 250 to 320			230	230	260
	PN 400			–	264	308
L1 ¹⁾	PN 40	34	40	90	90	100
	PN 63 to 160			105	105	115
	PN 250 to 320			115	115	130
	PN 400			–	132	154
H1	120 cm ²			122		
H4 with insulating section	PN 40 to 400			263		
H4 with bellows seal	PN 40 to 100			263		
	PN 160 to 325			365		
H2 or flange Ø D1	PN 40	23 ²⁾	23 ²⁾	90	95	115
	PN 63 to 160			100	105	140
	PN 250 to 320			125	130	160
	PN 400			125	145	180

¹⁾ Face-to-face dimensions of flanges according to DIN EN 558

²⁾ H2 = 28 mm with body material 2.4610

Table 5.2: Type 3271 and Type 3277 Pneumatic Actuators

Actuator area	cm ²	120
Diaphragm ØD	mm	168
H	mm	69
H3 ¹⁾	mm	110
H5	Type 3277 mm	88
Thread	Type 3271	M20x1.5
	Type 3277	M20x1.5
α	Type 3271	G 1/8 (1/8 NPT)

¹⁾ Minimum clearance required to remove the actuator

Table 6: Weights in kg**Table 6.1:** Type 3510 Valve

Port		Female thread	Welding ends	Flanges		
Valve		G/NPT	DN 10, 15, 25	DN 10	DN 15	DN 25
Valve without actuator	PN 40	1.7	1.5	2.9	3.1	4.2
	PN 63 to 160			3.9	4.2	7.3
	PN 250 to 320			5.6	6.0	8.7
	PN 400			7.1	9.1	9.8
Optional	Insulating section			0.5		
	Bellows seal PN 40 to 100			0.6		
	Bellows seal PN 160 to 325			0.9		

Table 6.2: Type 3271 and Type 3277 Pneumatic Actuators

Actuator area		cm ²	120
Weight ¹⁾	Type 3271	Without handwheel	kg (approx.) 2.5
		With handwheel	kg (approx.) 4
	Type 3277	Without handwheel	kg (approx.) 3.2
		With handwheel	kg (approx.) 4.5

¹⁾ The weights specified apply to a specific standard device configuration. Weights of other actuator configurations may differ depending on the version (material, number of actuator springs etc.).

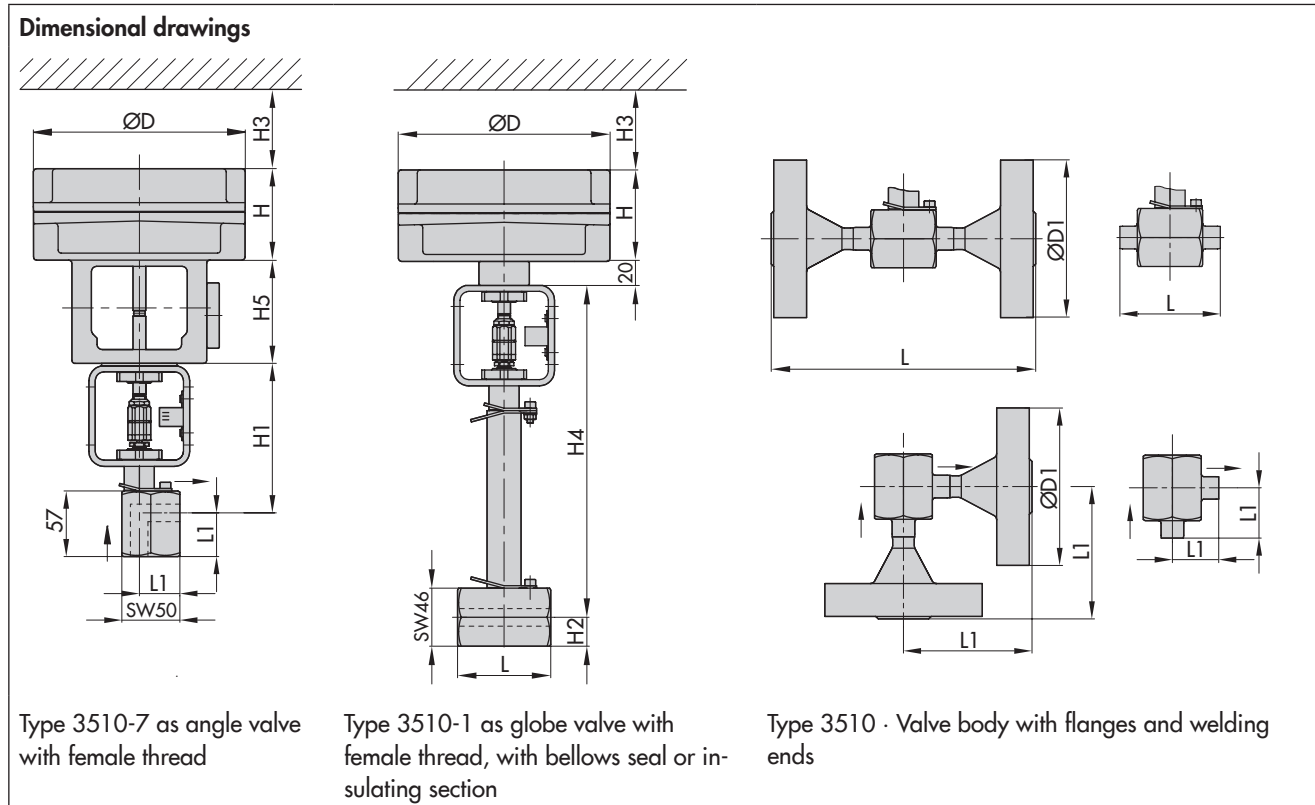

Ordering text

Type 3510 Micro-flow Valve	Globe or angle valve	Pneumatic actuator	Type 3271-5 or Type 3277-5, 120 cm ²
Valve size	DN	Fail-safe position	Fail-close or fail-open
Pressure rating	PN	Process medium	Density in kg/m ³ and temperature in °C
Body material	Refer to Table 2	Flow coefficient	kg/h or m ³ /h in standard or operating state
Type of connection	G or NPT female thread Flanges Welding ends	Pressure	p ₁ and p ₂ in bar (absolute pressure p _{abs}) (with minimum, normal and maximum flow rate)
Direction of flow	Flow-to-open or flow-to-close	Valve accessories*	Positioner and/or limit switch
Characteristic	Equal percentage, linear or on/off	*Mounting kit (1400-9031) required	